



Product Specification

AU OPTRONICS CORPORATION

(V) Preliminary Specifications

() Final Specifications

Module	15.6”(15.55”) HD 16:9 Color TFT-LCD with LED Backlight design
Model Name	B156XW02 V2 (H/W:4A)
Note ()	<i>LED Backlight with driving circuit design</i>

Customer	Date
_____	_____
Checked & Approved by	Date
_____	_____
<p>Note: This Specification is subject to change without notice.</p>	

Approved by	Date
_____	_____
Prepared by	Date
_____	_____
<p>NBBU Marketing Division AU Optronics corporation</p>	



Contents

1. Handling Precautions 4

2. General Description 5

 2.1 General Specification 5

 2.2 Optical Characteristics 6

3. Functional Block Diagram 11

4. Absolute Maximum Ratings..... 12

 4.1 Absolute Ratings of TFT LCD Module 12

 4.2 Absolute Ratings of Environment 12

5. Electrical Characteristics..... 13

 5.1 TFT LCD Module..... 13

 5.2 Backlight Unit 15

6. Signal Interface Characteristic..... 16

 6.1 Pixel Format Image 16

 6.2 The Input Data Format 17

 6.3 Integration Interface Requirement..... 18

 6.4 Interface Timing 20

7. Panel Reliability Test 22

 7.1 Vibration Test 22

 7.2 Shock Test 22

 7.3 Reliability Test..... 22

8. Mechanical Characteristics..... 23

 8.1 LCM Outline Dimension..... 23

 8.2 Screw Hole Depth and Center Position..... 25

9. Shipping and Package 26

 9.1 Shipping Label Format 26

 9.2 Carton Package..... 27

 9.3 Shipping Package of Palletizing Sequence..... 28

10. Appendix: EDID Description..... 29



Product Specification

AU OPTRONICS CORPORATION

Record of Revision

Version and Date	Page	Old description	New Description	Remark
0.0 2009/06/18	All	First Edition for Customer		
0.1 2009/09/07	26	Modify Label	Add CT label	

1. Handling Precautions

- 1) Since front polarizer is easily damaged, pay attention not to scratch it.
- 2) Be sure to turn off power supply when inserting or disconnecting from input connector.
- 3) Wipe off water drop immediately. Long contact with water may cause discoloration or spots.
- 4) When the panel surface is soiled, wipe it with absorbent cotton or other soft cloth.
- 5) Since the panel is made of glass, it may break or crack if dropped or bumped on hard surface.
- 6) Since CMOS LSI is used in this module, take care of static electricity and insure human earth when handling.
- 7) Do not open nor modify the Module Assembly.
- 8) Do not press the reflector sheet at the back of the module to any directions.
- 9) At the insertion or removal of the Signal Interface Connector, be sure not to rotate nor tilt the Interface Connector of the TFT Module.
- 11) After installation of the TFT Module into an enclosure (Notebook PC Bezel, for example), do not twist nor bend the TFT Module even momentary. At designing the enclosure, it should be taken into consideration that no bending/twisting forces are applied to the TFT Module from outside. Otherwise the TFT Module may be damaged.
- 12) Small amount of materials having no flammability grade is used in the LCD module. The LCD module should be supplied by power complied with requirements of Limited Power Source (IEC60950 or UL1950), or be applied exemption.
- 13) Disconnecting power supply before handling LCD modules, it can prevent electric shock, DO NOT TOUCH the electrode parts, cables, connectors and LED circuit part of TFT module that a LED light bar build in as a light source of back light unit. It can prevent electrostatic breakdown.



2. General Description

B156XW02 V2 is a Color Active Matrix Liquid Crystal Display composed of a TFT LCD panel, a driver circuit, and LED backlight system. The screen format is intended to support the 16:9 HD, 1366(H) x768(V) screen and 262k colors (RGB 6-bits data driver) with LED backlight driving circuit. All input signals are LVDS interface compatible.

B156XW02 V2 is designed for a display unit of notebook style personal computer and industrial machine.

2.1 General Specification

The following items are characteristics summary on the table at 25 °C condition:

Items	Unit	Specifications			
Screen Diagonal	[mm]	394.91			
Active Area	[mm]	344.23 X193.54			
Pixels H x V		1366x3(RGB) x 768			
Pixel Pitch	[mm]	0.2588X0.2588			
Pixel Format		R.G.B. Vertical Stripe			
Display Mode		Normally White			
White Luminance (ILED=20mA) (Note: ILED is LED current)	[cd/m ²]	200 typ. (5 points average) 170 min. (5 points average)			
Luminance Uniformity		1.25 max. (5 points)			
Contrast Ratio		500 typ			
Response Time	[ms]	8 typ / 16 Max			
Nominal Input Voltage VDD	[Volt]	+3.3 typ.			
Power Consumption	[Watt]	5.6 max. (Include Logic and Blu power)			
Weight	[Grams]	450 max.			
Physical Size Include bracket	[mm]		Min.	Typ.	Max.
		Length	-	359.3	360
		Width	-	209.5	210
		Thickness	-	-	5.5
Electrical Interface		1 channel LVDS			
Glass Thickness	[mm]	0.5			
Surface Treatment		Glare, Hardness 3H, Reflection 4.3%			
Support Color		262K colors (RGB 6-bit)			



Product Specification

AU OPTRONICS CORPORATION

Temperature Range Operating	[°C]	0 to +50
Storage (Non-Operating)	[°C]	-20 to +60
RoHS Compliance		RoHS Compliance

2.2 Optical Characteristics

The optical characteristics are measured under stable conditions at 25°C (Room Temperature) :

Item	Symbol	Conditions	Min.	Typ.	Max.	Unit	Note
White Luminance $I_{LED=20mA}$		5 points average	-	200	-	cd/m ²	1, 4, 5.
Viewing Angle	θ_R	Horizontal (Right) CR = 10 (Left)	40	45	-	degree	4, 9
	θ_L		40	45	-		
	ϕ_H	Vertical (Upper) CR = 10 (Lower)	10	15	-		
	ϕ_L		30	35	-		
Luminance Uniformity	δ_{5P}	5 Points	-	-	1.25		1, 3, 4
Luminance Uniformity	δ_{13P}	13 Points	-	-	1.65		2, 3, 4
Contrast Ratio	CR		-	500	-		4, 6
Cross talk	%				4		4, 7
Response Time	T_r	Rising	-	6	-	msec	4, 8
	T_f	Falling	-	2	-		
	T_{RT}	Rising + Falling	-	8	16		
Color / Chromaticity Coordinates	Red	Rx	CIE 1931	0.593	0.623	0.653	4
		Ry		0.321	0.351	0.381	
	Green	Gx		0.306	0.336	0.366	
		Gy		0.544	0.574	0.604	
	Blue	Bx		0.118	0.148	0.178	
		By		0.023	0.053	0.083	
	White	Wx		0.263	0.313	0.343	
		Wy		0.279	0.329	0.359	
	NTSC	%			-	60	

Note 1: 5 points position (Ref: Active area)



Note 2: 13 points position (Ref: Active area)



Note 3: The luminance uniformity of 5 or 13 points is defined by dividing the maximum luminance values by the minimum test point luminance

$$\delta_{W5} = \frac{\text{Maximum Brightness of five points}}{\text{Minimum Brightness of five points}}$$

$$\delta_{W13} = \frac{\text{Maximum Brightness of thirteen points}}{\text{Minimum Brightness of thirteen points}}$$

Note 4: Measurement method

The LCD module should be stabilized at given temperature for 30 minutes to avoid abrupt temperature change during measuring. In order to stabilize the luminance, the measurement should be executed after lighting

Backlight for 30 minutes in a stable, windless and dark room, and it should be measured in the center of screen.

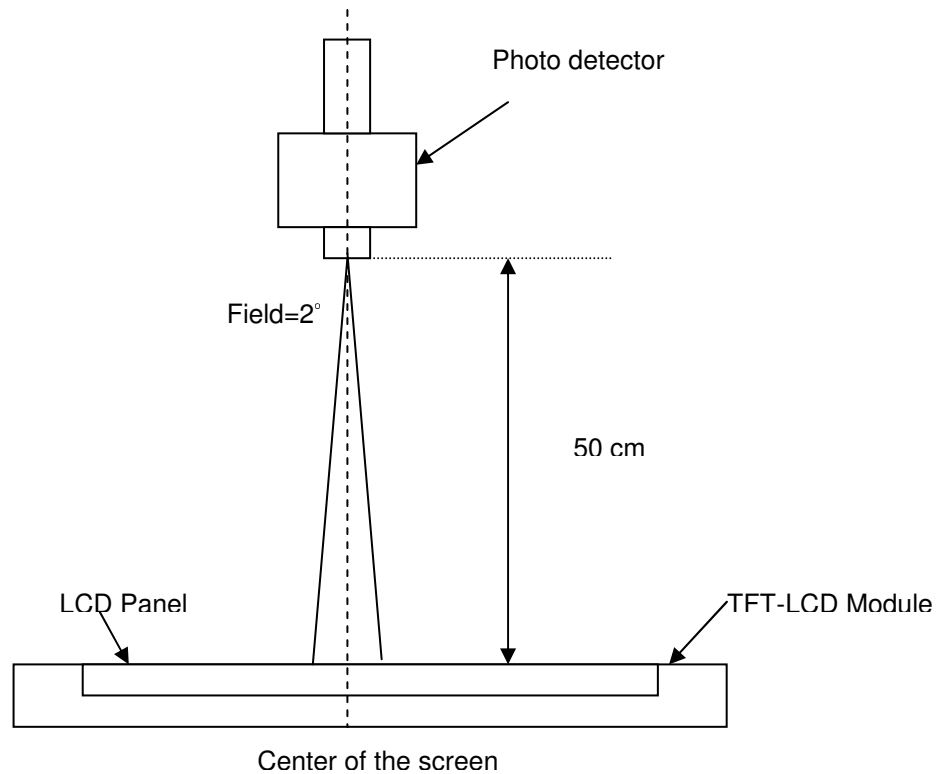

Note 5 : Definition of Average Luminance of White (Y_L):

Measure the luminance of gray level 63 at 5 points , $Y_L = [L (1)+ L (2)+ L (3)+ L (4)+ L (5)] / 5$

$L (x)$ is corresponding to the luminance of the point X at Figure in Note (1).

Note 6 : Definition of contrast ratio:

Contrast ratio is calculated with the following formula.

$$\text{Contrast ratio (CR)} = \frac{\text{Brightness on the "White" state}}{\text{Brightness on the "Black" state}}$$

Note 7 : Definition of Cross Talk (CT)

$$CT = |Y_B - Y_A| / Y_A \times 100 (\%)$$

Where

Y_A = Luminance of measured location without gray level 0 pattern (cd/m^2)

Y_B = Luminance of measured location with gray level 0 pattern (cd/m^2)

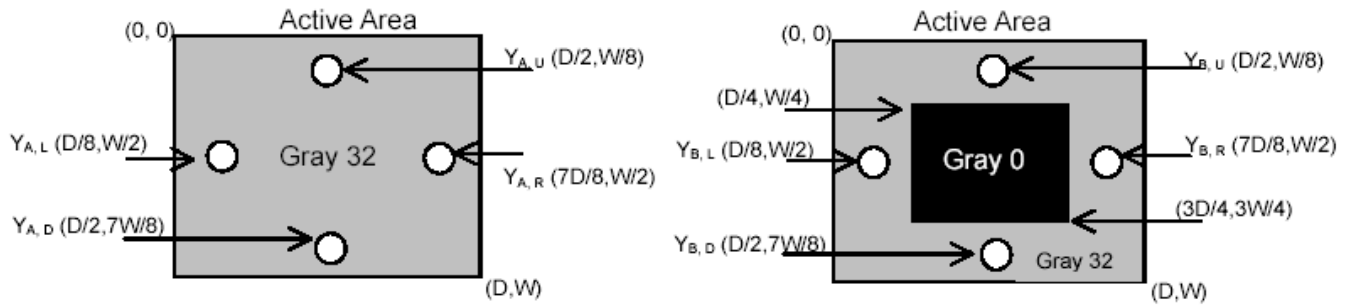

Note 8: Definition of response time:

The output signals of BM-7 or equivalent are measured when the input signals are changed from "Black" to "White" (falling time) and from "White" to "Black" (rising time), respectively. The response time interval between the 10% and 90% of amplitudes. Refer to figure as below.

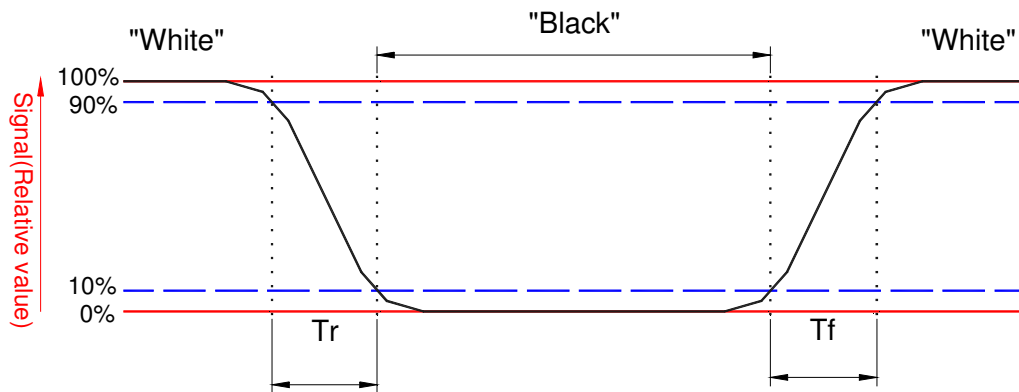

Note 9. Definition of viewing angle

Viewing angle is the measurement of contrast ratio ≥ 10 , at the screen center, over a 180° horizontal and 180° vertical range (off-normal viewing angles). The 180° viewing angle range is broken down as follows; 90° (θ) horizontal left and right and 90° (ϕ) vertical, high (up) and low (down). The measurement direction is typically perpendicular to the display surface with the screen rotated about its center to develop the desired measurement viewing angle.

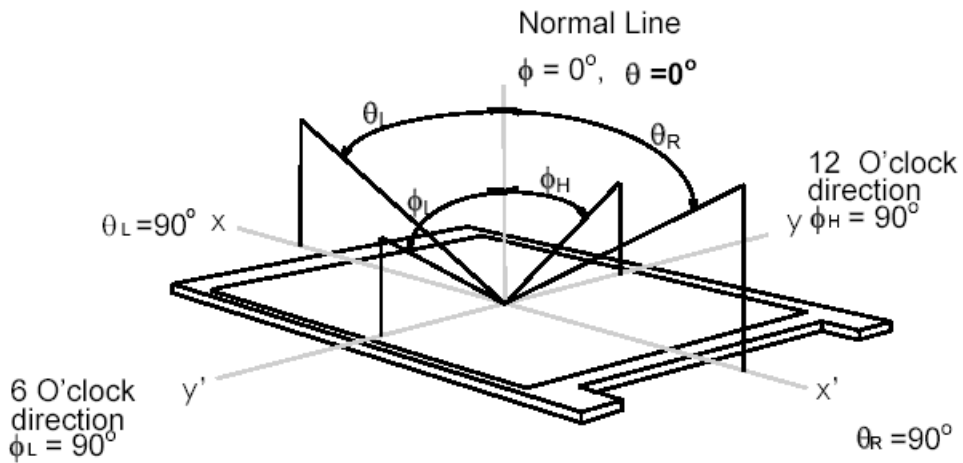

3. Functional Block Diagram

The following diagram shows the functional block of the 15.6 inches wide Color TFT/LCD 40 Pin one channel Module

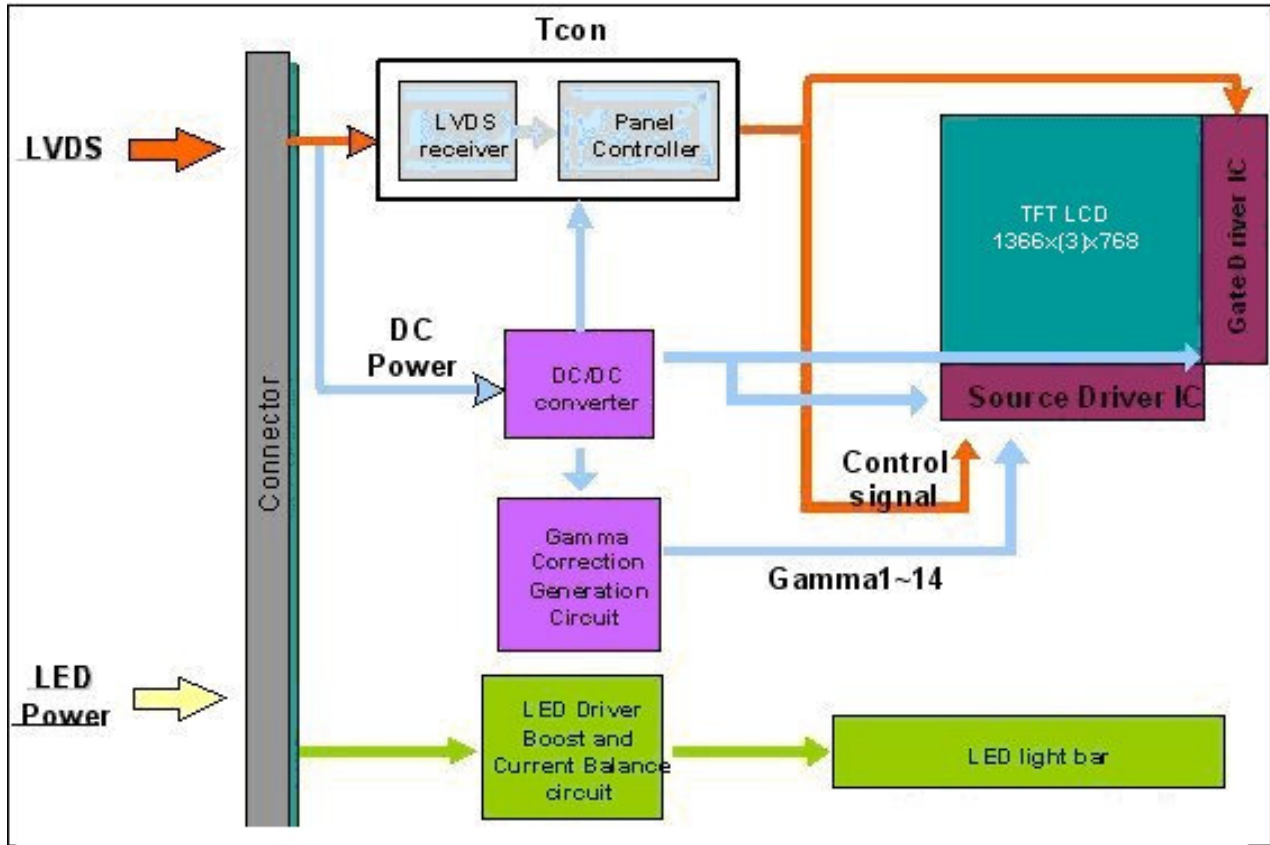

4. Absolute Maximum Ratings

An absolute maximum rating of the module is as following:

4.1 Absolute Ratings of TFT LCD Module

Item	Symbol	Min	Max	Unit	Conditions
Logic/LCD Drive Voltage	Vin	-0.3	+4.0	[Volt]	Note 1,2

4.2 Absolute Ratings of Environment

Item	Symbol	Min	Max	Unit	Conditions
Operating Temperature	TOP	0	+50	[°C]	Note 4
Operation Humidity	HOP	5	95	[%RH]	Note 4
Storage Temperature	TST	-20	+60	[°C]	Note 4
Storage Humidity	HST	5	95	[%RH]	Note 4

Note 1: At Ta (25°C)

Note 2: Permanent damage to the device may occur if exceed maximum values

Note 3: LED specification refer to section 5.2

Note 4: For quality performance, please refer to AUO IIS (Incoming Inspection Standard).

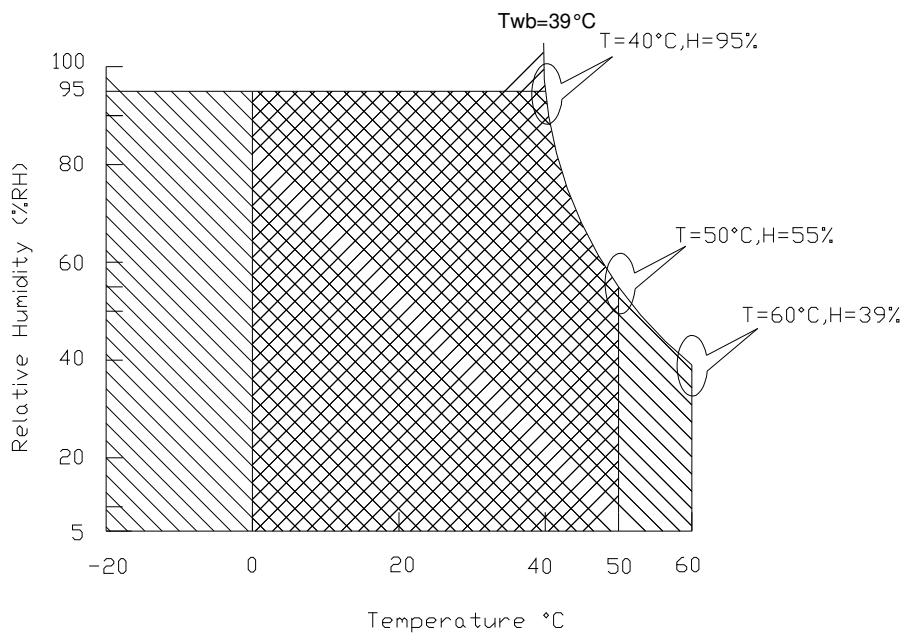

Operating Range 

Storage Range

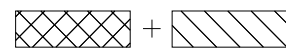

5. Electrical Characteristics

5.1 TFT LCD Module

5.1.1 Power Specification

Input power specifications are as follows;

The power specification are measured under 25°C and frame frequency under 60Hz

Symble	Parameter	Min	Typ	Max	Units	Note
VDD	Logic/LCD Drive Voltage	3.0	3.3	3.6	[Volt]	
PDD	VDD Power	-	-	1.2	[Watt]	Note 1
IDD	IDD Current	-	250	400	[mA]	Note 1
IRush	Inrush Current	-	-	1500	[mA]	Note 2
VDDrp	Allowable Logic/LCD Drive Ripple Voltage	-	-	100	[mV] p-p	

Note 1 : Maximum Measurement Condition : Black Pattern at 3.3V driving voltage. ($P_{max} = V_{3.3} \times I_{black}$)

Note 2 : Measure Condition

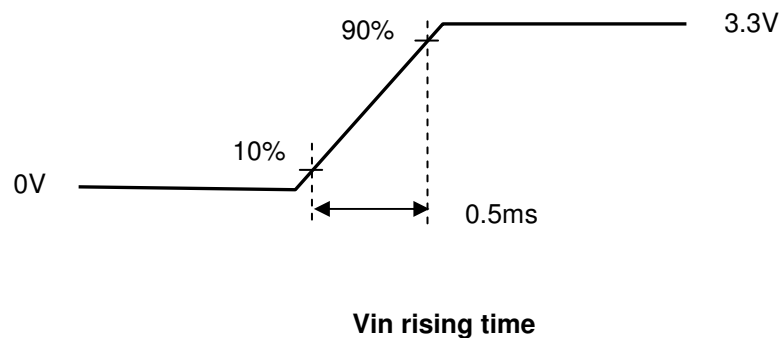
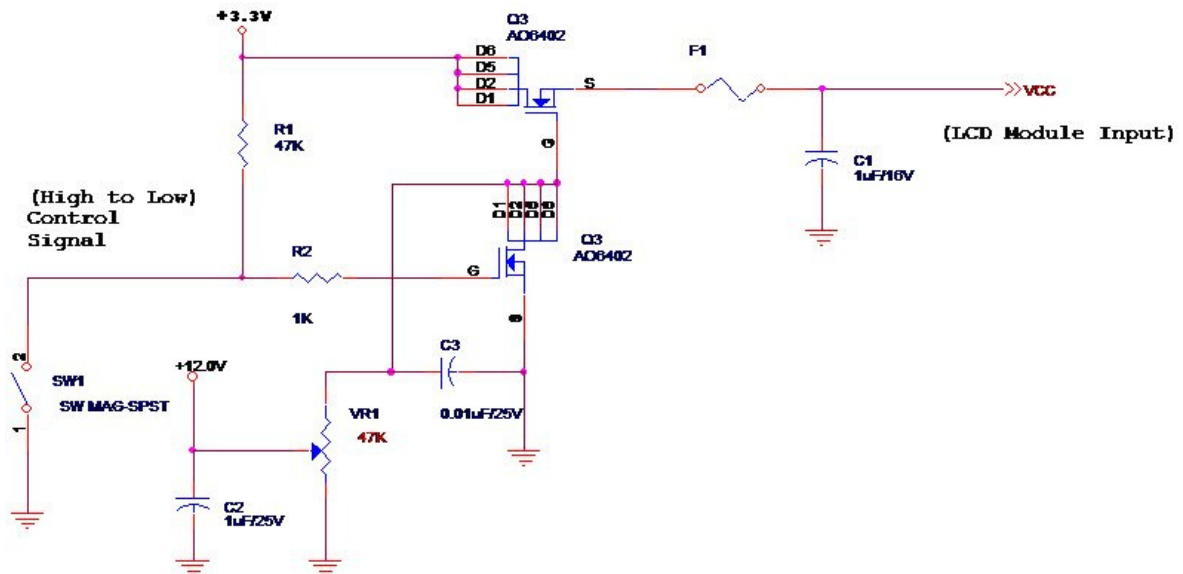

5.1.2 Signal Electrical Characteristics

Input signals shall be low or High-impedance state when VDD is off.

Signal electrical characteristics are as follows;

Parameter	Condition	Min	Max	Unit
V_{th}	Differential Input High Threshold ($V_{cm}=+1.2V$)		100	[mV]
V_{tl}	Differential Input Low Threshold ($V_{cm}=+1.2V$)	-100	-	[mV]
V_{ID}	Differential Input Voltage	100	600	[mV]
V_{cm}	Differential Input Common Mode Voltage	1.125	1.375	[V]

Note: LVDS Signal Waveform

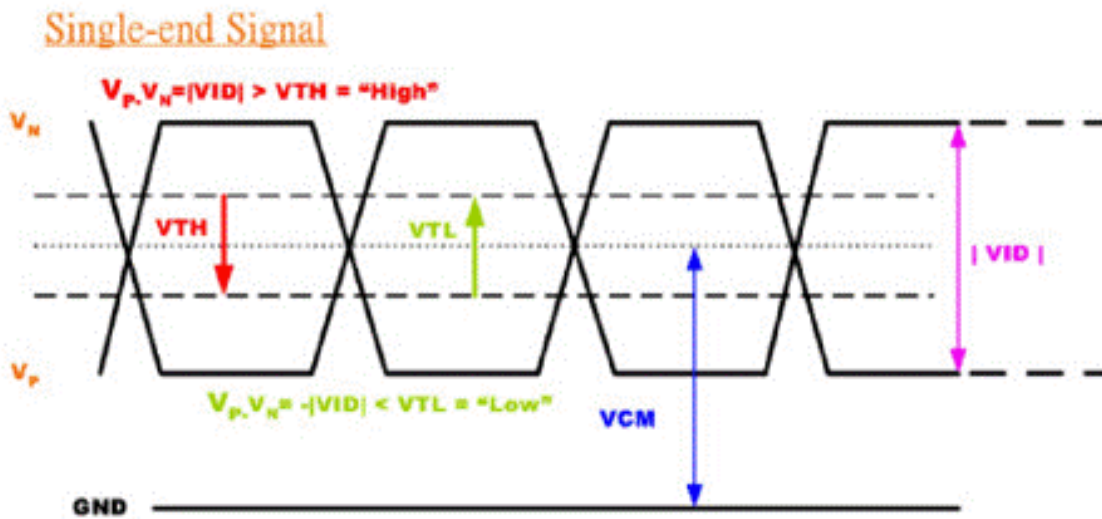



Product Specification

AU OPTRONICS CORPORATION

5.2 Backlight Unit

5.2.1 LED characteristics

Parameter	Symbol	Min	Typ	Max	Units	Condition
Backlight Power Consumption	PLED	-	-	TBD	[Watt]	(Ta=25°C), Note 1 Vin =12V
LED Life-Time	N/A	10,000	-	-	Hour	(Ta=25°C), Note 2 If=20 mA

Note 1: Calculator value for reference $P_{LED} = VF$ (Normal Distribution) * I_F (Normal Distribution) / Efficiency

Note 2: The LED life-time define as the estimated time to 50% degradation of initial luminous.

5.2.2 Backlight input signal characteristics

Parameter	Symbol	Min	Typ	Max	Units	Remark
LED Power Supply	VLED	6.0	12.0	21.0	[Volt]	Define as Connector Interface (Ta=25°C)
LED Enable Input High Level	VLED_EN	2.5	-	5.5	[Volt]	
LED Enable Input Low Level		-	-	0.8	[Volt]	
PWM Logic Input High Level	VPWM_EN	2.5	-	5.5	[Volt]	
PWM Logic Input Low Level		-	-	0.8	[Volt]	
PWM Input Frequency	FPWM	100	--	TBD	Hz	
PWM Duty Ratio	Duty	5	--	100	%	

6. Signal Interface Characteristic

6.1 Pixel Format Image

Following figure shows the relationship of the input signals and LCD pixel format.

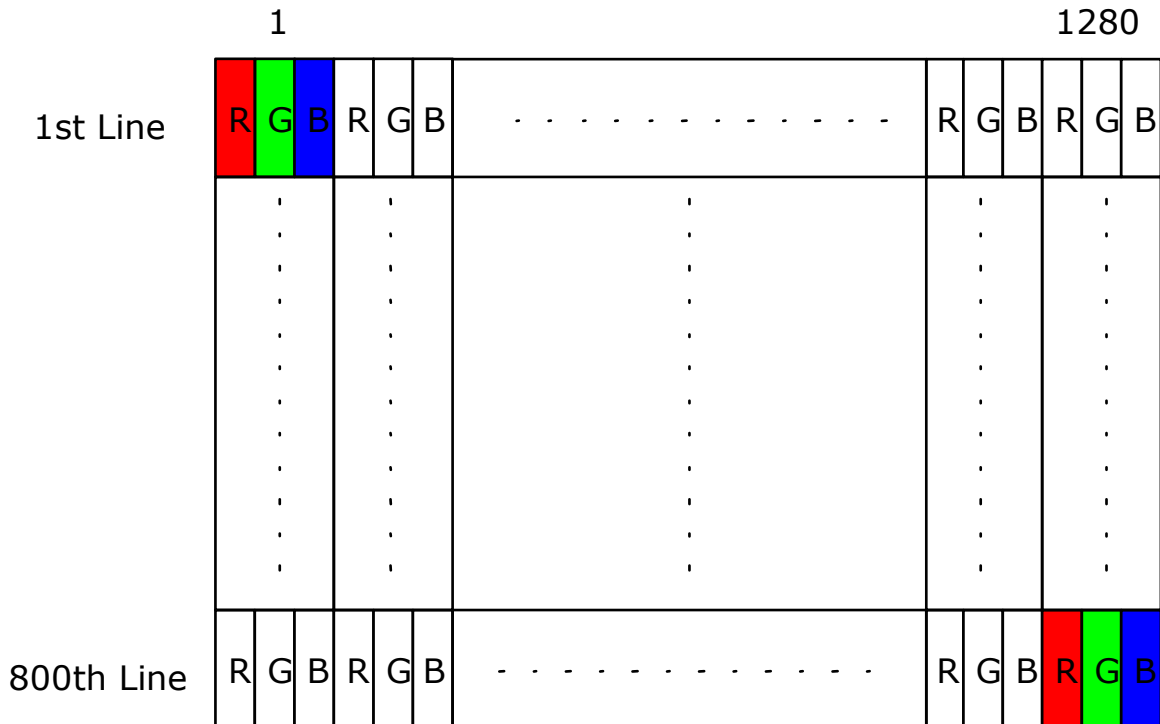

6.2 The Input Data Format

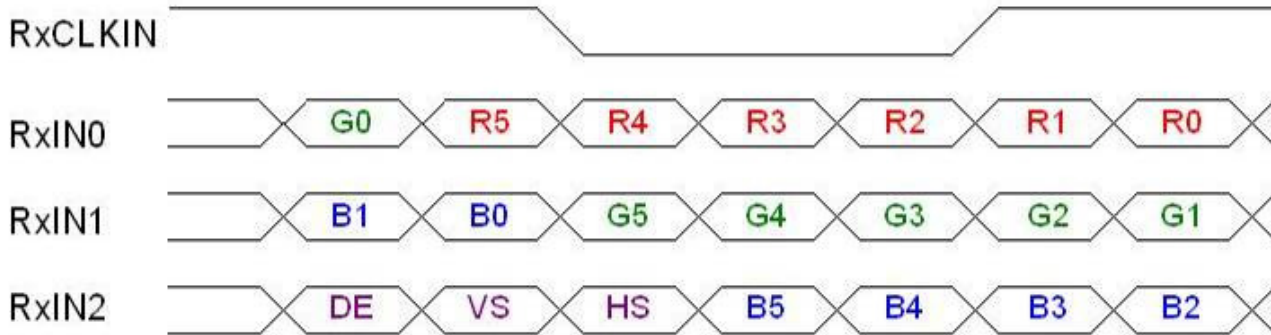

Signal Name	Description	
R5 R4 R3 R2 R1 R0	Red Data 5 (MSB) Red Data 4 Red Data 3 Red Data 2 Red Data 1 Red Data 0 (LSB)	Red-pixel Data Each red pixel's brightness data consists of these 6 bits pixel data.
G5 G4 G3 G2 G1 G0	Green Data 5 (MSB) Green Data 4 Green Data 3 Green Data 2 Green Data 1 Green Data 0 (LSB)	Green-pixel Data Each green pixel's brightness data consists of these 6 bits pixel data.
B5 B4 B3 B2 B1 B0	Blue Data 5 (MSB) Blue Data 4 Blue Data 3 Blue Data 2 Blue Data 1 Blue Data 0 (LSB)	Blue-pixel Data Each blue pixel's brightness data consists of these 6 bits pixel data.
RxCLKIN	Data Clock	The signal is used to strobe the pixel data and DE signals. All pixel data shall be valid at the falling edge when the DE signal is high.
DE	Display Timing	This signal is strobed at the falling edge of RxCLKIN. When the signal is high, the pixel data shall be valid to be displayed.
VS	Vertical Sync	The signal is synchronized to RxCLKIN .
HS	Horizontal Sync	The signal is synchronized to RxCLKIN .

Note: Output signals from any system shall be low or High-impedance state when VDD is off.

6.3 Integration Interface Requirement

6.3.1 Connector Description

Physical interface is described as for the connector on module.

These connectors are capable of accommodating the following signals and will be following components.

Connector Name / Designation	For Signal Connector
Manufacturer	IPEX or compatible
Type / Part Number	IPEX 20455-040E-12R or compatible
Mating Housing/Part Number	IPEX 20455-043T-12 or compatible

6.3.2 Pin Assignment

LVDS is a differential signal technology for LCD interface and high speed data transfer device.

PIN#	Signal Name	Description
1	NC	No Connection (Reserve)
2	VDD	Power Supply +3.3V
3	VDD	Power Supply +3.3V
4	VEDID	EDID +3.3V Power
5	NC	No Connect (Reserve)
6	CLK_EDID	EDID Clock Input
7	DAT_EDID	EDID Data Input
8	RxOIN0-	-LVDS Differential Data INPUT(Odd R0-R5,G0)
9	RxOIN0+	+LVDS Differential Data INPUT(Odd R0-R5,G0)
10	VSS	Ground
11	RxOIN1-	-LVDS Differential Data INPUT(Odd G1-G5,B0-B1)
12	RxOIN1+	+LVDS Differential Data INPUT(Odd G1-G5,B0-B1)
13	VSS	Ground
14	RxOIN2-	-LVDS Differential Data INPUT(Odd B2-B5,HS,VS,DE)
15	RxOIN2+	+LVDS Differential Data INPUT(Odd B2-B5,HS,VS,DE)
16	VSS	Ground
17	RxOCKIN-	-LVDS Odd Differential Clock INPUT
18	RxOCKIN+	-LVDS Odd Differential Clock INPUT
19	VSS	Ground
20	NC	No connection
21	NC	No connection
22	NC	No connection

23	NC	No connection
24	NC	No connection
25	NC	No connection
26	NC	No connection
27	NC	No connection
28	NC	No connection
29	NC	No connection
30	NC	No connection
31	VLED_GND	LED Ground
32	VLED_GND	LED Ground
33	VLED_GND	LED Ground
34	NC	No Connection (Reserve)
35	VPWM_EN	PWM logic input level
36	VLED_EN	LED enable input level
37	NC	No Connection (Reserve)
38	VLED	LED Power Supply 6-21V
39	VLED	LED Power Supply 6-21V
40	VLED	LED Power Supply 6-21V

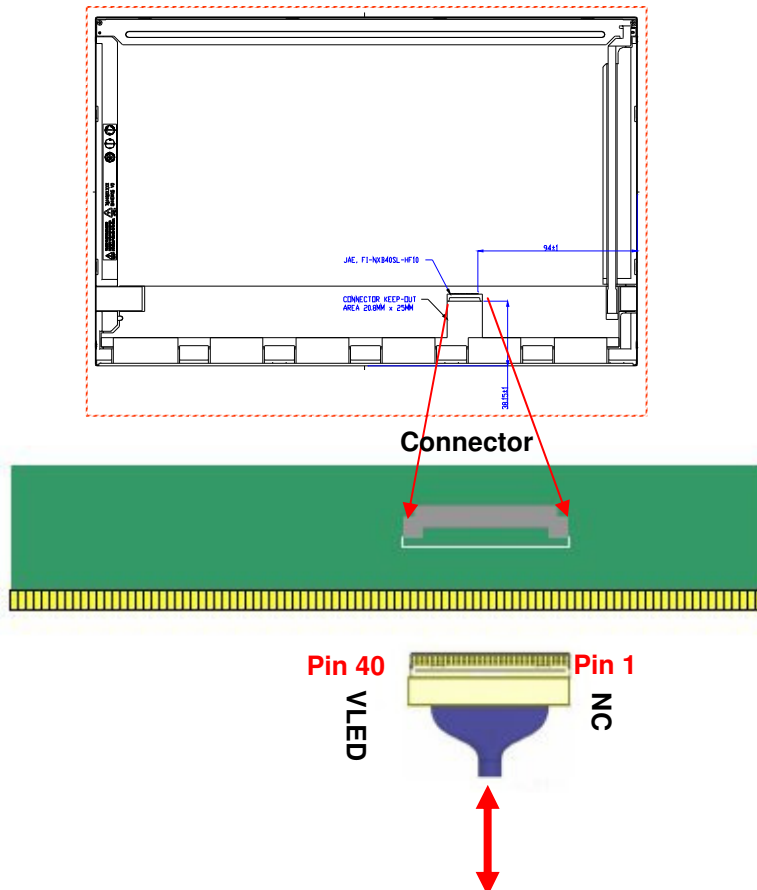

Note1: Input signals shall be low or High-impedance state when VDD is off.

6.4 Interface Timing

6.4.1 Timing Characteristics

Basically, interface timings should match the 1366x768 /60Hz manufacturing guide line timing.

Parameter	Symbol	Min.	Typ.	Max.	Unit	
Frame Rate	-	50	60	TBD	Hz	
Clock frequency	$1/T_{\text{Clock}}$	65	69.3	72	MHz	
Vertical Section	Period	T_V	776	808	1023	T_{Line}
	Active	T_{VD}	768			
	Blanking	T_{VB}	8	40	255	
Horizontal Section	Period	T_H	1396	1606	2047	T_{Clock}
	Active	T_{HD}	1366			
	Blanking	T_{HB}	30	240	681	

Note : DE mode only

6.4.2 Timing diagram

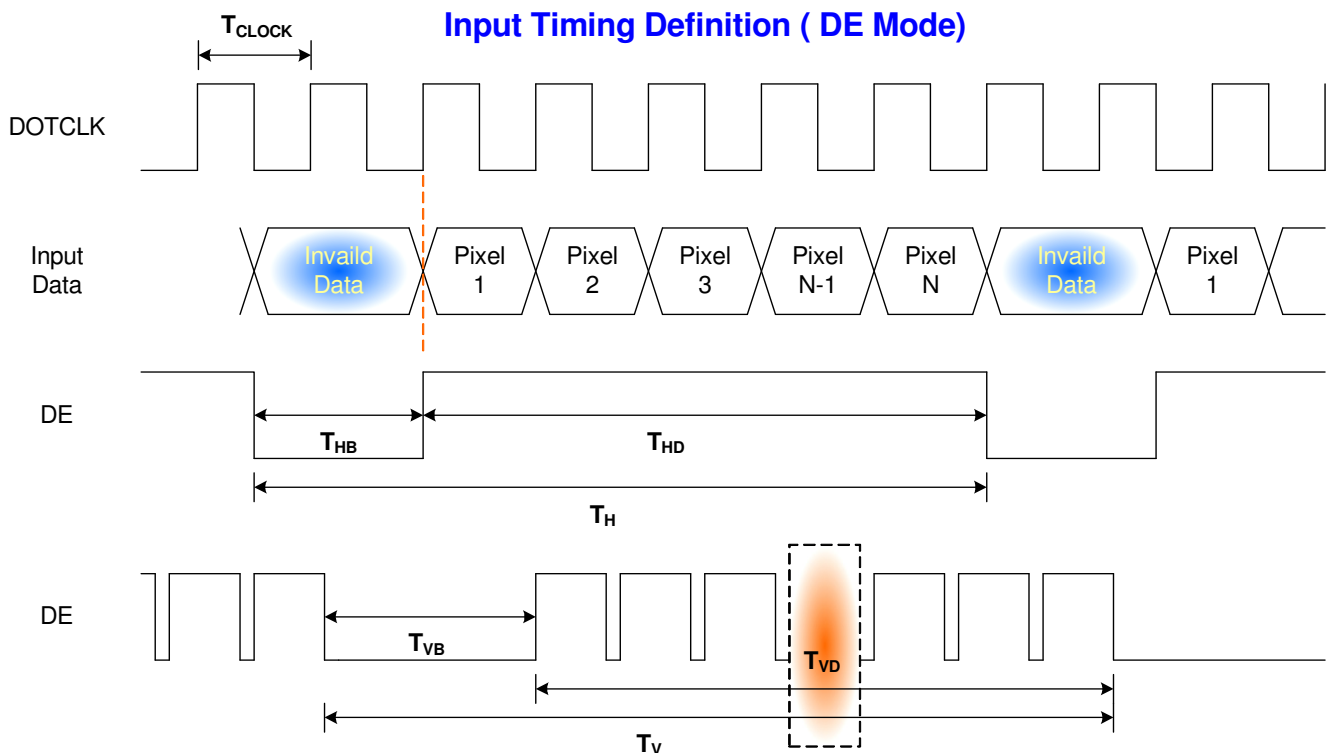

6.5 Power ON/OFF Sequence

Power on/off sequence is as follows. Interface signals and LED on/off sequence are also shown in the chart. Signals from any system shall be Hi-Z state or low level when VDD is off

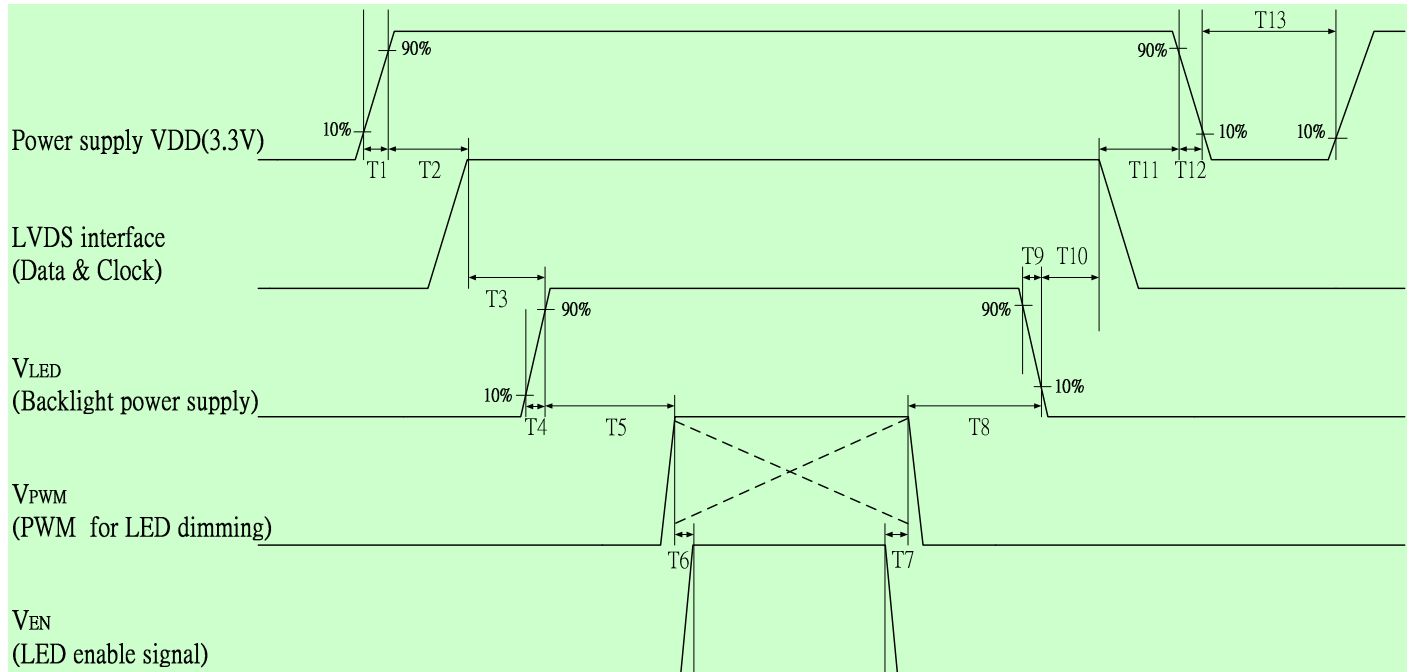

Power Sequence Timing				
Parameter	Value			Units
	Min.	Typ.	Max.	
T1	0.5	-	10	ms
T2	0	-	50	
T3	0	-	50	
T4	0.5	-	10	
T5	10	-	-	
T6	10	-	-	
T7	0	-	-	
T8	10	-	-	
T9	0	-	10	
T10	200	-	-	
T11	0.5	-	50	
T12	0	-	10	
T13	400	-	-	

Note: If T3, T5, T6 couldn't match above specifications, must request $T3+T5+T6 > 200\text{ms}$ at least

7. Panel Reliability Test

7.1 Vibration Test

Test Spec:

- Test method: Non-Operation
- Acceleration: 1.5 G
- Frequency: 10 - 500Hz Random
- Sweep: 30 Minutes each Axis (X, Y, Z)

7.2 Shock Test

Test Spec:

- Test method: Non-Operation
- Acceleration: 220 G , Half sine wave
- Active time: 2 ms
- Pulse: X,Y,Z .one time for each side

7.3 Reliability Test

Items	Required Condition	Note
Temperature Humidity Bias	Ta= 40°C, 90%RH, 300h	
High Temperature Operation	Ta= 50°C, Dry, 300h	
Low Temperature Operation	Ta= 0°C, 300h	
High Temperature Storage	Ta= 60°C, 35%RH, 300h	
Low Temperature Storage	Ta= -20°C, 50%RH, 250h	
Thermal Shock Test	Ta=-20°C to 60°C, Duration at 30 min, 100 cycles	
ESD	Contact : ±8 KV Air : ±15 KV	Note 1

Note1: According to EN 61000-4-2 , ESD class B: Some performance degradation allowed. No data lost
 . Self-recoverable. No hardware failures.

Remark: MTBF (Excluding the LED): 30,000 hours with a confidence level 90%

8. Mechanical Characteristics

8.1 LCM Outline Dimension

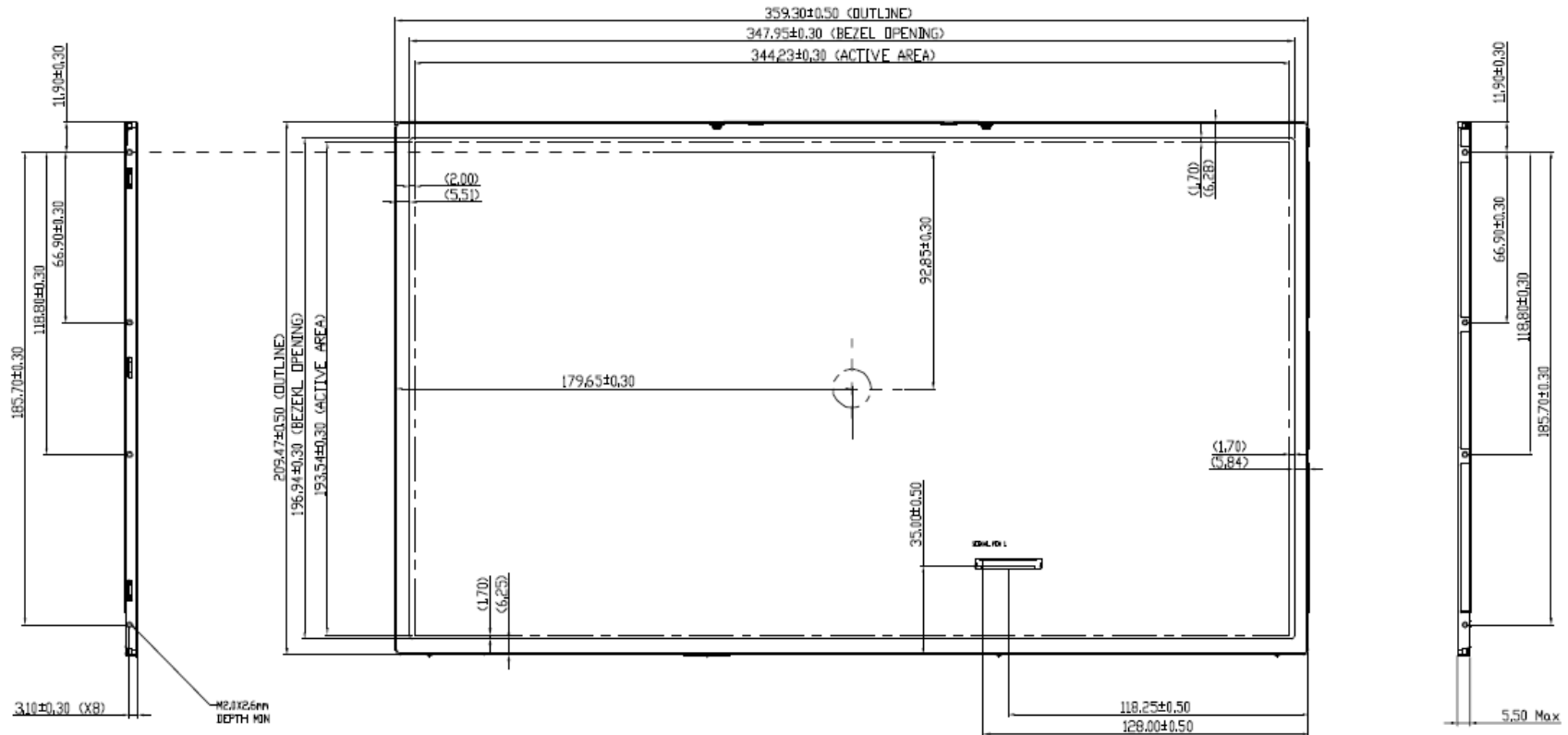

Front view 2D drawing

Product Specification

AU OPTRONICS CORPORATION

Remind RD Solid line and dotted line

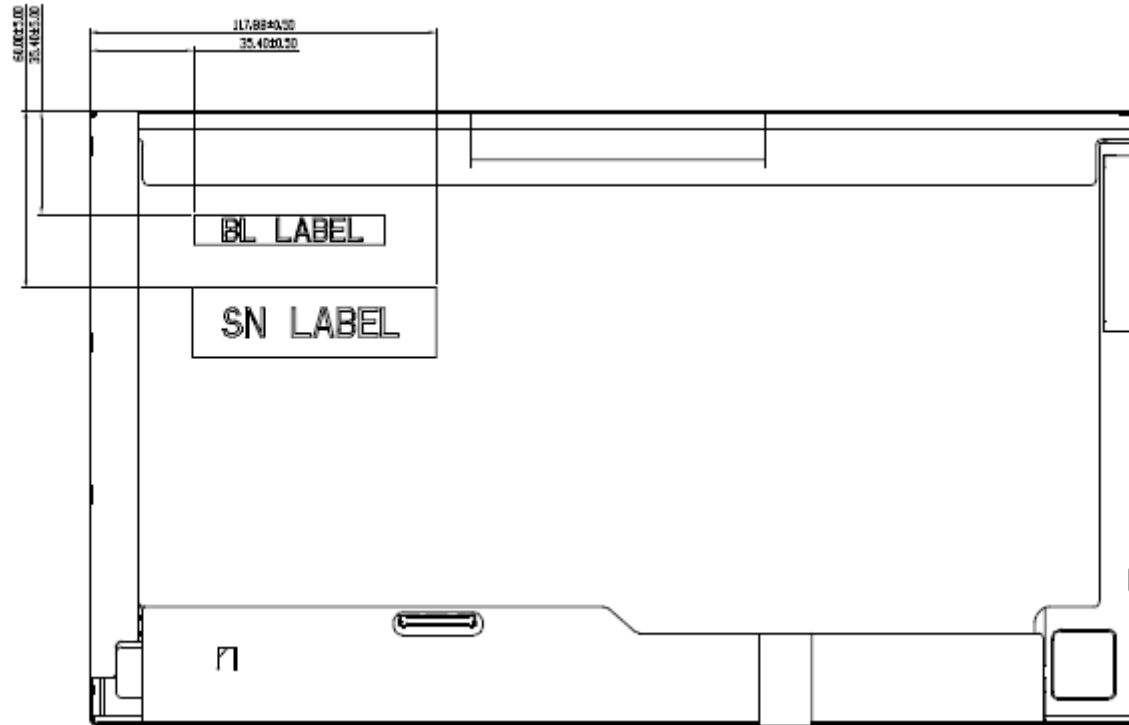

Note: Prevention IC damage, IC positions not allowed any overlap over these areas.

8.2 Screw Hole Depth and Center Position

Maximum Screw penetration from side surface is 2.6 mm

The center of screw hole center location is $3.1 \pm 0.3\text{mm}$ from front surface

Screw Torque: Maximum 2.5 kgf-cm

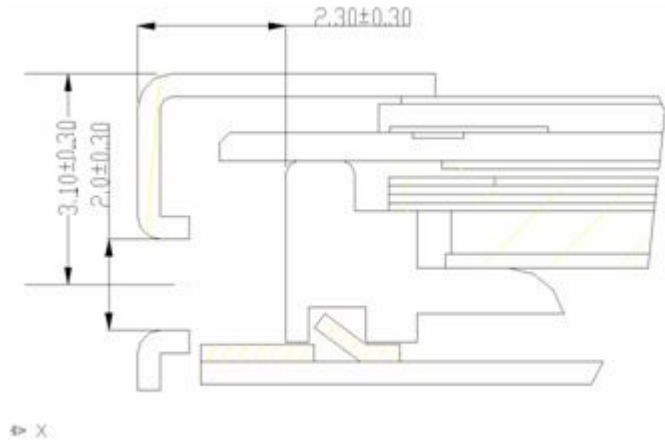

9. Shipping and Package

9.1 Shipping Label Format

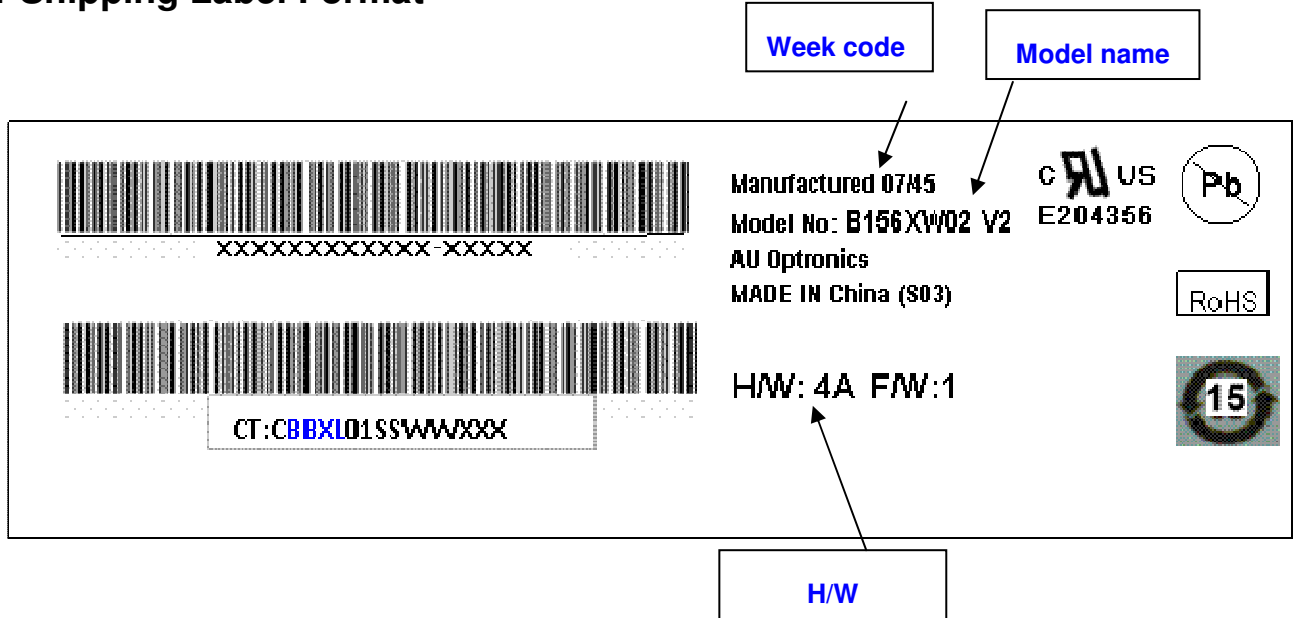

9.2 Carton Package

The outside dimension of carton is 437(L)mm x 369 (W)mm x 313 (H)mm

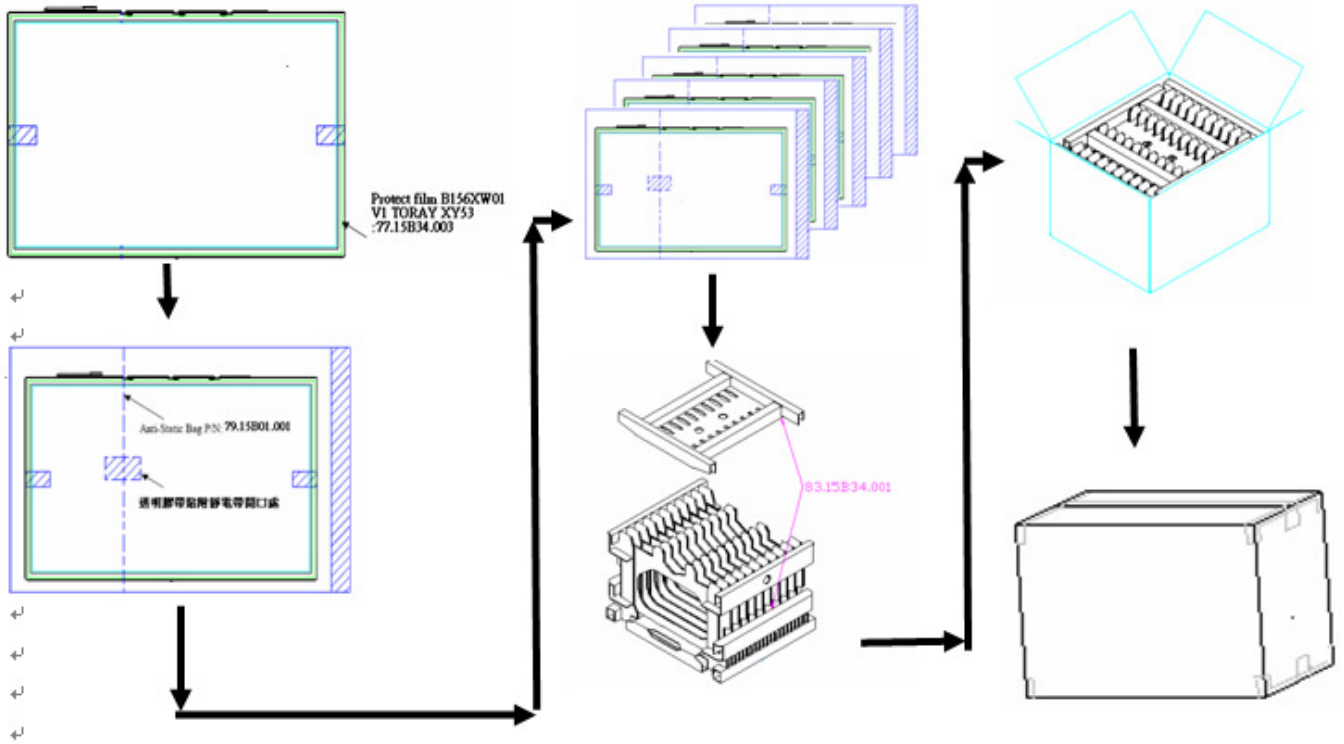

9.3 Shipping Package of Palletizing Sequence

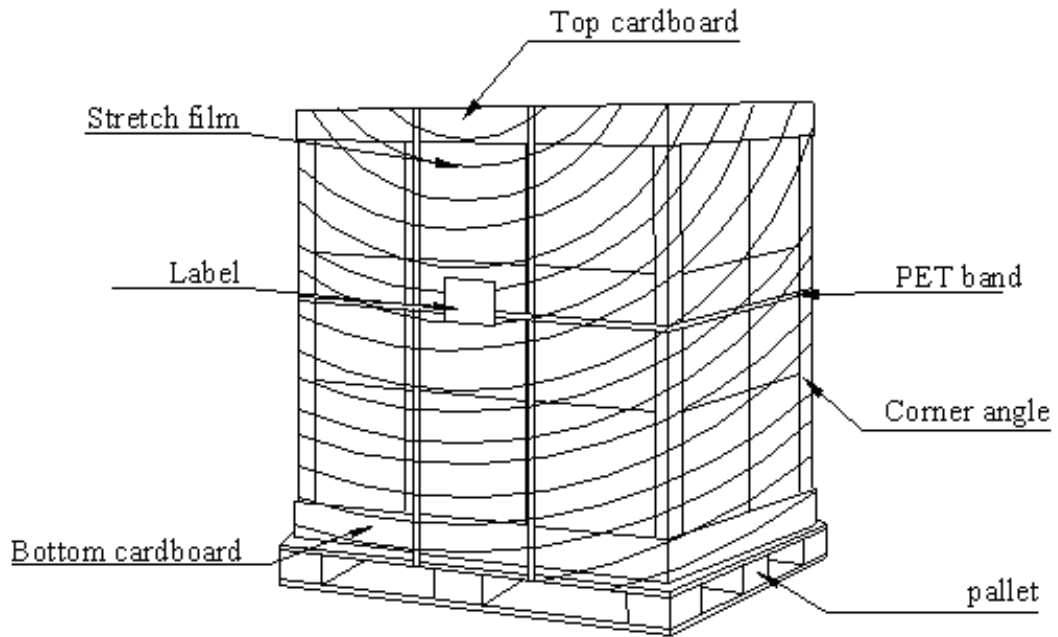



10. Appendix: EDID Description

Address	Value	Value	Value
HEX	HEX	BIN	DEC
00	00	00000000	0
01	FF	11111111	255
02	FF	11111111	255
03	FF	11111111	255
04	FF	11111111	255
05	FF	11111111	255
06	FF	11111111	255
07	00	00000000	0
08	06	00000110	6
09	AF	10101111	175
0A	EC	11101100	236
0B	22	00100010	34
0C	00	00000000	0
0D	00	00000000	0
0E	00	00000000	0
0F	00	00000000	0
10	01	00000001	1
11	13	00010011	19
12	01	00000001	1
13	03	00000011	3
14	80	10000000	128
15	22	00100010	34
16	13	00010011	19
17	78	01111000	120
18	0A	00001010	10
19	C8	11001000	200
1A	95	10010101	149
1B	9E	10011110	158
1C	57	01010111	87
1D	54	01010100	84
1E	92	10010010	146
1F	26	00100110	38
20	0F	00001111	15
21	50	01010000	80
22	54	01010100	84
23	00	00000000	0
24	00	00000000	0
25	00	00000000	0
26	01	00000001	1
27	01	00000001	1
28	01	00000001	1
29	01	00000001	1
2A	01	00000001	1
2B	01	00000001	1



Product Specification

AU OPTRONICS CORPORATION

2C	01	00000001	1
2D	01	00000001	1
2E	01	00000001	1
2F	01	00000001	1
30	01	00000001	1
31	01	00000001	1
32	01	00000001	1
33	01	00000001	1
34	01	00000001	1
35	01	00000001	1
36	12	00010010	18
37	1B	00011011	27
38	56	01010110	86
39	42	01000010	66
3A	50	01010000	80
3B	00	00000000	0
3C	26	00100110	38
3D	30	00110000	48
3E	20	00100000	32
3F	18	00011000	24
40	34	00110100	52
41	00	00000000	0
42	58	01011000	88
43	C1	11000001	193
44	10	00010000	16
45	00	00000000	0
46	00	00000000	0
47	18	00011000	24
48	00	00000000	0
49	00	00000000	0
4A	00	00000000	0
4B	0F	00001111	15
4C	00	00000000	0
4D	00	00000000	0
4E	00	00000000	0
4F	00	00000000	0
50	00	00000000	0
51	00	00000000	0
52	00	00000000	0
53	00	00000000	0
54	00	00000000	0
55	00	00000000	0
56	00	00000000	0
57	00	00000000	0
58	00	00000000	0
59	20	00100000	32
5A	00	00000000	0



Product Specification

AU OPTRONICS CORPORATION

5B	00	00000000	0
5C	00	00000000	0
5D	FE	11111110	254
5E	00	00000000	0
5F	41	01000001	65
60	55	01010101	85
61	4F	01001111	79
62	0A	00001010	10
63	20	00100000	32
64	20	00100000	32
65	20	00100000	32
66	20	00100000	32
67	20	00100000	32
68	20	00100000	32
69	20	00100000	32
6A	20	00100000	32
6B	20	00100000	32
6C	00	00000000	0
6D	00	00000000	0
6E	00	00000000	0
6F	FE	11111110	254
70	00	00000000	0
71	42	01000010	66
72	31	00110001	49
73	35	00110101	53
74	36	00110110	54
75	58	01011000	88
76	57	01010111	87
77	30	00110000	48
78	32	00110010	50
79	20	00100000	32
7A	56	01010110	86
7B	32	00110010	50
7C	20	00100000	32
7D	0A	00001010	10
7E	00	00000000	0
7F	C0	11000000	192
SUM			6144